

ORIGINAL ONLY WITH THE DIAMOND



# WITA ISOT LAIPPA PUMPUT go.max F



**pump technology  
& more...**

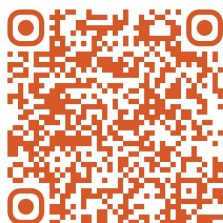

go.tec H  
LÄMMITYS

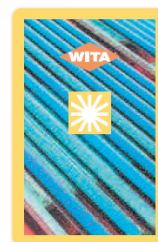

go.tec S  
AURINKO



go.tec G  
LÄMPÖPUMPUT

## Product feature

- 5-year warranty
- SmartAdapt function
- Anti-blocking function
- LED power indicator



**EEL**  
≤0.23

## Technical data

Maximum delivery head	12 m
Maximum flow rate	37 m <sup>3</sup> /h
Power consumption	750 W
Control	Constant characteristic curves, Constant pressure characteristic curves, Proportional characteristic curves
Additional function	Smart Adapt, Automatic Night Mode
Supply voltage	1 x 230 V, 50 Hz
Motor protection	No external motor protection required
Protection class	IPX4D
Insulation class	F
Ambient temperature	0 °C to 40 °C
Media temperature	2 °C to 95 °C
Temperature class	TF 95 gem. DIN EN 60335-2-51
Max. system pressure	1.0 MPa   10 bar
Connection sizes	DN50, DN65
Installation lengths	280mm, 340 mm
Pump housing material	Cast iron with cataphoretic coating
EEL	≤ 0.23
More models up to DN80 will be available in Q3 2025	

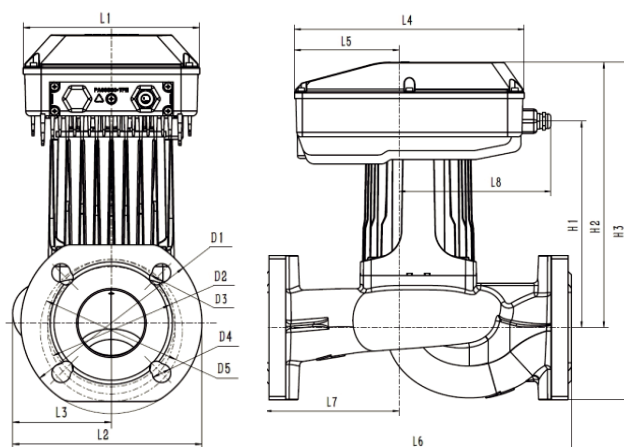

	L1	L2	L3	L4	L5	L6	L7	L8
50-12F-280	180	169	86	255	138	280	140	147
65-12F-340	180	194	101	255	138	340	170	147
	D1	D2	D3	D4	D5	H1	H2	H3
50-12F-280	165	110	14	19	125	226	292	362
65-12F-340	185	117	14	19	145	229	295	375

WITA go.max F 50-12F-280

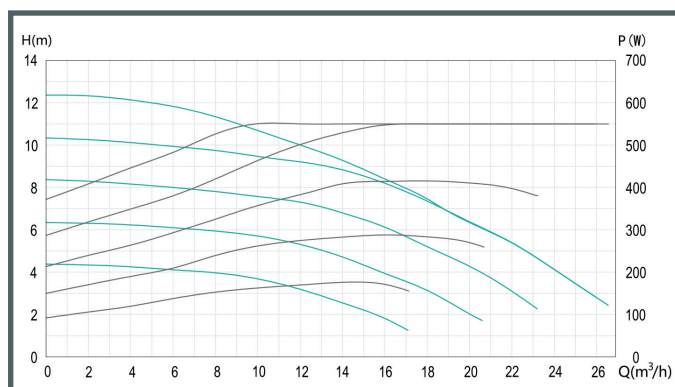

WITA go.max F 65-12F-340

